

**magnetic field sensor  
for pneumatic cylinders  
BIM-UNR-AP6X**

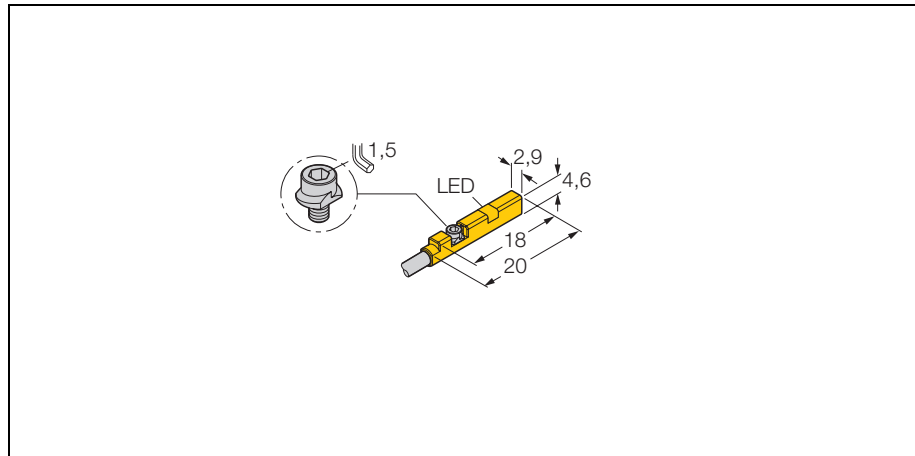

- For C-groove cylinders without mounting accessories
- Optional accessories for mounting on other cylindrical housings.
- One-hand mounting possible
- Stable mounting
- Magneto-resistive sensor
- DC 3-wire, 10...30 VDC
- NO contact, PNP output
- Cable connection

**Wiring diagram**

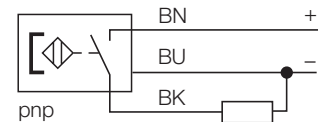

**Functional principle**

Magnetic field sensors are activated by magnetic fields and are especially suited for piston position detection in pneumatic cylinders. Based on the fact that magnetic fields can permeate non-magnetizable metals, it is possible to detect a permanent magnet attached to the piston through the aluminium wall of the cylinder.

<b>Type</b>	BIM-UNR-AP6X
Ident-No.	4685830
<b>Pass speed</b>	≤ 3 m/s
Repeatability	≥ ± 0.1 mm
Temperature drift	≤ 0.1 mm
Hysteresis	≤ 1 mm
Ambient temperature	-25...+ 70 °C
<b>Operating voltage</b>	10... 30VDC
Residual ripple	≤ 10 % U <sub>SS</sub>
DC rated operational current	≤ 100 mA
No-load current I <sub>0</sub>	≤ 15 mA
Residual current	≤ 0.1 mA
Rated insulation voltage	≤ 0.5 kV
Short-circuit protection	yes / cyclic
Voltage drop at I <sub>e</sub>	≤ 1.8V
Wire breakage / Reverse polarity protection	yes / complete
Output function	3-wire, NO, pnp
Switching frequency	≤ 0.3kHz
<b>Housing</b>	rectangular, UNR
Dimensions	25.7 x 2.9 x 4.6 mm
Housing material	plastic, PP
Material active face	plastic, PP
Tightening torque fixing screw	0.2 Nm
Electrical connection	cable
Cable quality	Ø 2, grey, Lif9Y-11Y, PUR, 2 m
Cable cross section:	3 x 0.08mm <sup>2</sup>
Litz wire	40 x 0.05mm <sup>2</sup>
Vibration resistance	55 Hz (1 mm)
Shock resistance	30g (11 ms)
Degree of protection	IP67
Mounting on the following profiles	. 

<b>Display switch state</b>	LED yellow
Included in scope of supply	cable clip

## magnetic field sensor for pneumatic cylinders BIM-UNR-AP6X

### Mounting instructions

### mounting instructions

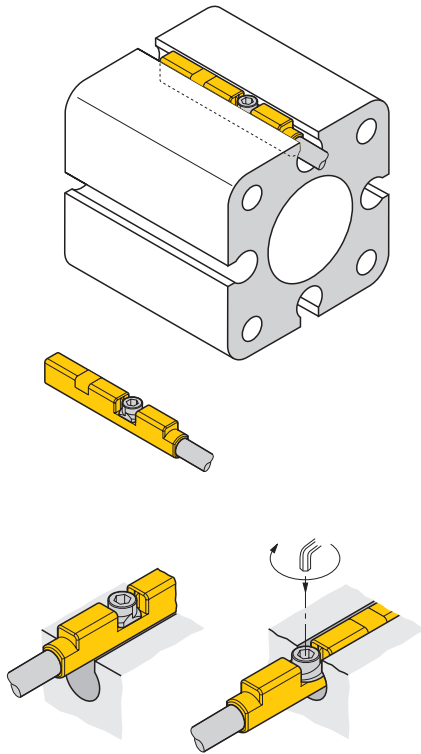

One-hand mounting of the sensor in the groove from the top. The sensor can be mounted as follows with the patented wing screw: The wing screws and the female thread feature a left-hand thread. Two small plastic lips keep the screw in position and guarantee a ready-to-install sensor on delivery. With clockwise rotation, the screw is removed from the thread and hits the upper grooves with the wings. As a consequence, the sensor is pressed down and is thus locked. A quarter turn of the screw with a standard screw driver or a 1.5 mm Allen key is enough for vibration resistant mounting. The allowed fixing torque of 0.2 Nm is sufficient for safe mounting without damaging the cylinder. Cable clips are included in the scope of delivery to enable smooth cable routing in the groove. Accessories for mounting on other cylindrical housings have to be ordered separately.